



RELAY-8 8 Relay Output Board

User Manual



HAGSTROM
ELECTRONICS, INC.

Toll Free 888-690-9080

Phone: **(540) 465-4677** Fax: **(540) 465-4678**
Monday through Friday, 8:00 am to 5:00 pm (EST)

sales@hagstromelectronics.com
www.hagstromelectronics.com

1986 Junction Road, Strasburg, VA 22657

Table of Contents

Introduction and Setup of the RELAY-8	2
RELAY-8 Serial Communication Protocol	3-4
Accessories	5
RELAY-8 Connections	6

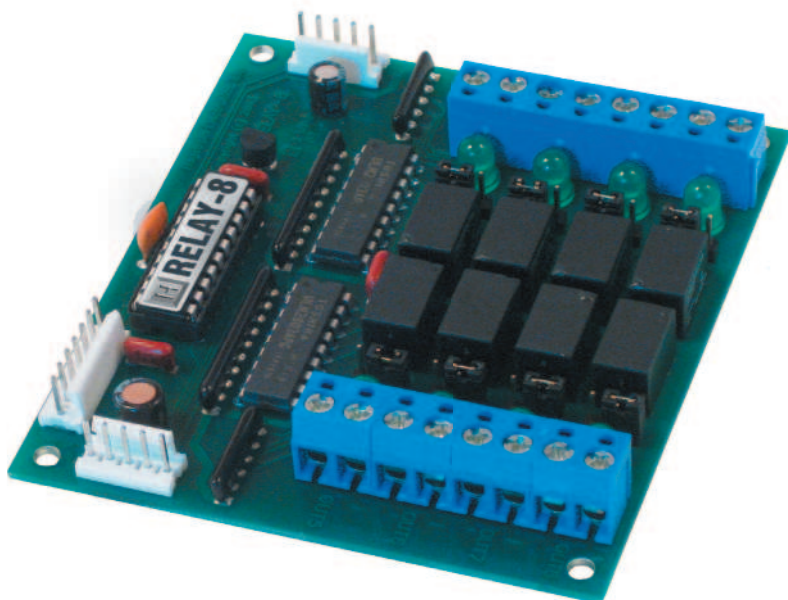

Thank you for purchasing the
HAGSTROM ELECTRONICS, INC.
RELAY-8. This product is may be configured
in a variety of ways to meet your specific
requirements. Please take a few minutes to
read this manual before using your RELAY-8.

The **HAGSTROM ELECTRONICS, INC.** RELAY-8 module may be used in a variety of control applications. This unit operates as a stand-alone device, with communication supplied as Logic Level serial data or through one of our interface cables for RS-232 operation.

Unit Setup:

- 1.** Set the Communication Address of the module according to the Input Header table shown on the **RELAY-8 Connections** page. Modules may be daisy chained together, provided each unit has its own address. No address jumpers are necessary if only one module is being used.
- 2.** Each relay output on the RELAY-8 board can be configured for normally open or normally closed operation. The relays each have a corresponding three position jumper which allows the contact mode to be set. For operation with normally open contacts, place the jumper block across the pins designated as “NO.”(Factory default). For normally closed operation, move the jumper block to “NC.”

When configured as “NO,” the relay contacts are closed when the relay is activated, and open when the relay is off. For “NC” operation, the relay contacts open when the relay is activated, and are closed when the relay is off.

- 3.** With power off, connect the Communication cable to the unit, as well as a power supply (5V DC only) for the device. See diagram (**Power Header 1** and **Power Header 2**) for details regarding the connection to the communication and power ports.

If daisy chaining units together, use our 5 pin MTA cable between units to provide power and signal communication between the modules. Attach the Communication cable to the 5 pin header on the first module in the daisy chain and attach the power supply to the 5 pin header on the last module in the chain.

- 4.** With power off, make the connections on the screw terminal headers for each of the relay outputs to be used.
- 5.** Apply power to the unit. All relays are in the off state at power on.
- 6.** Communicate serial data to the unit using a program incorporating the protocol outlined in the manual or on the included CD.

RELAY-8 Serial Communication Protocol

The RELAY-8 features two simple commands which allow the setting and reading of the relay states. For setting the relay states, a “Set Relay Status” command packet is sent to the unit. To read the current state of the relays, a “Read Relay Status “ command is transmitted to the RELAY-8.

All communication to and from the RELAY-8 is performed at 9600, 8, N, 1 serial settings.

Note that all relays are in the inactive state at power on.

“Set Relay Status” - 0x02 Command

This command packet consists of 4 bytes which indicate the desired on and off states of the 8 relays of a particular RELAY-8 unit.

Byte 1 = 0x90 Indicates the address of the board (see Address Selection section).

Byte 2 = 0x02 Command to write the Relay Status

Byte 3 = 0x0N Where N is a byte value between 0x00 and 0x0F which dictates the desired state of relays 5-8 of the RELAY-8 addressed in Byte 1.
Bit 0: Relay 5 (1 = On, 0 = Off)
Bit 1: Relay 6 (1 = On, 0 = Off)
Bit 2: Relay 7 (1 = On, 0 = off)
Bit 3: Relay 8 (1 = On, 0 = Off)

Byte 4 = 0x0N Where N is a byte value between 0x00 and 0x0F which dictates the desired state of relays 1-4 of the RELAY-8 addressed in Byte 1.
Bit 0: Relay 1 (1 = On, 0 = Off)
Bit 1: Relay 2 (1 = On, 0 = Off)
Bit 2: Relay 3 (1 = On, 0 = off)
Bit 3: Relay 4 (1 = On, 0 = Off)

No response is returned from the RELAY-8 when this packet is received.

“Read Relay Status” - 0x03 Command

This command packet consists of 2 bytes which requests the current on and off states of the 8 relays of a particular unit.

Byte 1 = 0x90 Indicates the address of the board (see address select section).

Byte 2 = 0x03 Command to read the Relay Status

A single byte is returned from the RELAY-8 when this packet is received which indicates the status of the relays of the unit addressed by byte 1 of the packet. The response byte format:

Bit 0: Relay 1 (1 = Relay 1 is On, 0 = Relay 1 is Off)
Bit 1: Relay 2 (1 = Relay 2 is On, 0 = Relay 2 is Off)
Bit 2: Relay 3 (1 = Relay 3 is On, 0 = Relay 3 is Off)
Bit 3: Relay 4 (1 = Relay 4 is On, 0 = Relay 4 is Off)
Bit 4: Relay 5 (1 = Relay 5 is On, 0 = Relay 5 is Off)
Bit 5: Relay 6 (1 = Relay 6 is On, 0 = Relay 6 is Off)
Bit 6: Relay 7 (1 = Relay 7 is On, 0 = Relay 7 is Off)
Bit 7: Relay 8 (1 = Relay 8 is On, 0 = Relay 8 is Off)

Note that the RELAY-8 uses electromechanical relays and there is a typical delay of approximately 10msec for the relay to respond to an electrically commanded state.

Address Selection

The RELAY-8 is capable of being daisy chained to other RELAY-8 devices to provide more relays under the same communication port control. The **Address Select Input Header** of the RELAY-8 provides a jumper configuration for setting the particular unit address (see the **RELAY-8 Connections** diagram). Byte 1 of the command packet determines which RELAY-8 is being addressed. The 0x90 value for byte 1 would address the unit for relays 1-8. A 0x91 would address a RELAY-8 which is jumper configured for controlling relays 9-16. Up to eight RELAY-8 units may be daisy chained, making the address byte in the packet valid from 0x90 to 0x97.

A sample program is included on the CD as a demonstration of communication with the RELAY-8.

Accessories

KE-PWR5/2A Power Supply (USA/Canada orders only)
5V/2A regulated DC. Use to supply power to the RELAY-8.



MTA100-5-36-FF Cable Set
36 inches long. MTA style headers. May be used to “daisy-chain” multiple RELAY-8 units.



KE-232-IF Interface Cable 4 feet. Use to connect the RELAY-8 logic level serial data to the PC RS-232 port.



RELAY-8 Connections

Address Select Input Header (Selects Communication Address)

Board Address	Jumper Pins
Relays 1-8	none
Relays 9-16	6,7
Relays 17-24	5,7
Relays 25-32	5,6,7
Relays 33-40	4,7
Relays 41-48	4,6,7
Relays 49-56	4,5,7
Relays 57-64	4,5,6,7

The **Address Select Input Header** is for use with daisy chaining multiple RELAY-8 modules under control of the same serial connection. For a single unit, leave all address jumpers off of the address select input header.

Power Header 1 and **Power Header 2** provide connection points to the power and communication signals for the unit. These connectors are identical in pinout, and either connector can be used for power, communication, or daisy chaining to another module. In the case of daisy chaining, power supplied at one module will be propagated to the others in the same daisy chain.

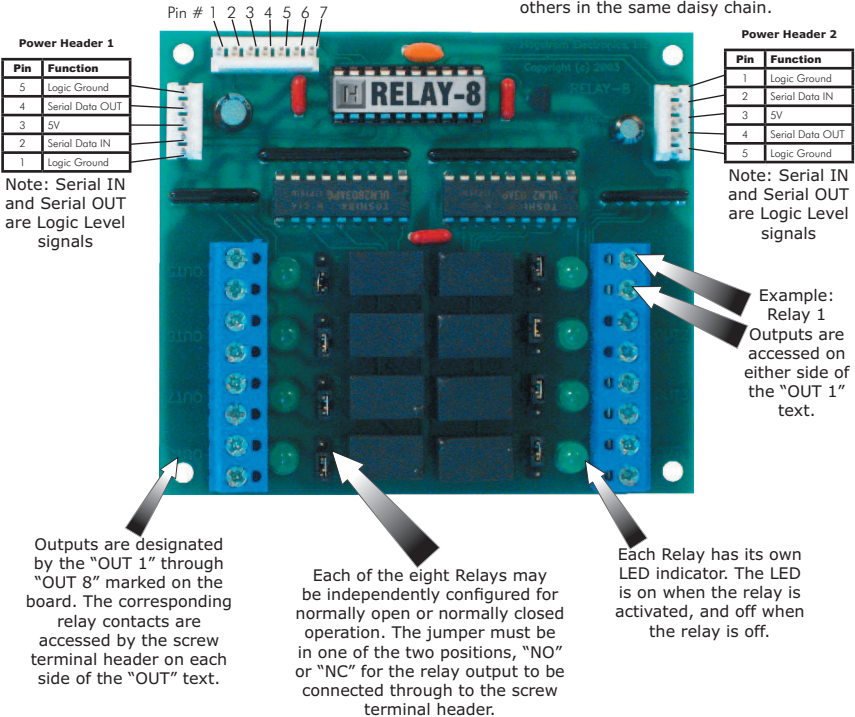

RELAY-8 Specifications

Board Dimensions	Length = 3.5", Width = 3.05"
Mounting Hole Size	.125" Dia (4)
Operating Voltage	5V DC Regulated +/- 5%
Operating Current	350 ma Maximum at 5.00 V
Operating Temp.	0 to 70 Degrees C
Communication	Serial 9600, 8, N, 1 Logic Level
Relay Rated Load	1 Amp, 24 VDC, .50 Amp at 125 VAC

Warranty

HAGSTROM ELECTRONICS, INC. warrants this product against defects in material or workmanship for a period of ONE YEAR from the original purchase date. We will repair or replace (at our option) the returned defective unit at no charge during this warranty period.

No responsibility is assumed for any special, incidental, or consequential damage resulting from the use of or inability to use this product. In no case is **HAGSTROM ELECTRONICS, INC.** to be liable for any amount which exceeds the purchase price of the unit, regardless of the claim.

No other warranty, written or verbal, is authorized. This warranty is applicable only to units sold in the United States. Units sold outside the United States are covered by a similar warranty.

Depending on the state in which you live, you may have additional rights.

Great care has been taken during the assembly, testing, and burn-in of your RELAY-8 to ensure its performance. If you have any questions, help is available Monday through Friday, 8:00 am to 5:00 pm (EST). Call Toll Free **888-690-9080**, or **(540) 465-4677**.

NOTICE The RELAY-8 product is designed to be used by technically oriented computer users. When the RELAY-8 is in use, signals and voltages are present on the unit. Prudent handling and packaging is necessary to prevent damage to the RELAY-8 or devices it is connected with.

This product is designed for OEM use, and is not FCC part 15 approved. Because the packaging and use of the product will directly affect the characteristics of the unit, it is the responsibility of the purchaser to obtain final approval of their application, if required.